

Composition of Probe System

RPS-20M radio probe system include two pieces of hardware and one software package; The software package model is SP-W10, the two pieces of the hardware are:

- 1) RP610M radio probe (including optional shank and stylus);
- 2) RSI-20D radio receiver(the standard cable length 8m/the optional lengthened cable).

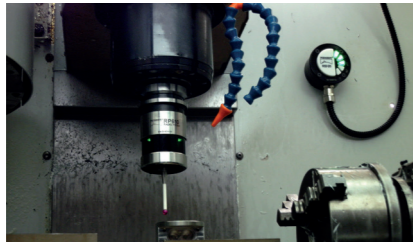

Technical Parameters

- 1) The technical parameters of RP610M radio probe :
 - ◆ Stylus sensing direction: $\pm X, \pm Y, +Z$;
 - ◆ Stylus sensing over-travel : $X-Y \pm 12^\circ, Z +5 \text{ mm}$;
 - ◆ The adjusting range of trigger force in Z direction: 500-1000 g;
 - ◆ Trigger force in X-Y surface: 100g-160g;
 - ◆ Unidirectional repeatability (2σ) : $\leq 1 \mu\text{m}$;
 - ◆ Radio signal receiving/sending distance : $\leq 14 \text{ m}$;
 - ◆ Working days of new batteries (5% utilization rate in a single shift):280-320 days;
 - ◆ Seal grade: IP68.
- 2) RSI-20D radio receiver technical parameters:
 - ◆ Radio signal receiving/sending distance: $\leq 14 \text{ m}$;
 - ◆ Input voltage is $24\text{V} \pm 10\%$ (DC) and output load current is 50 mA.

Technical Characteristics

- ◆ Probe switch on/off method: M code on/off;
- ◆ Radio code signals are used to transmit information between the probe and the receiver. The time to transmit and to decode a group of signals is less than 1ms;
- ◆ The transmission frequency of the radio signal is within 2.4 G-2.483 G, the number of transmission channel is 16;
- ◆ Output four kinds of SSR signals to machine control system when probe is in the states of trigger、 error、 probe batteries low and output pulse;
- ◆ The RSI-20D receiver can change its logical state of the output signal by setting;
- ◆ The LED lights in the receiver show the working status of the probe system.

Applicable equipment

- ◆ Various specifications of machine center, CNC boring-milling machine, drilling machine center and so on.
- ◆ Various specifications of CNC lathes, turning machine center, CNC turning-milling machine center.

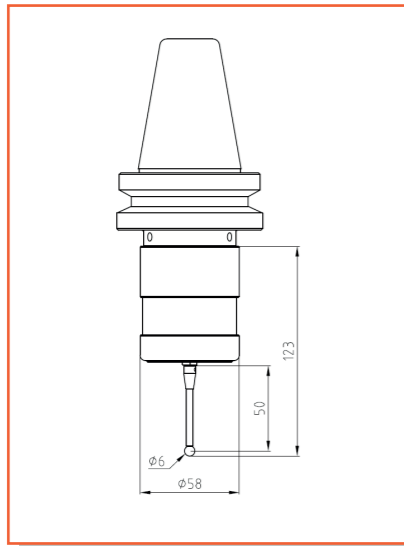

Application

- ◆ Setting work-piece coordinate system and machining zero points automatically before processing;
- ◆ Detect and control the key dimensions, position coordinates and their precision automatically between two processes;
- ◆ Detect precision of the key dimensions, shapes, position after processing.

Basic configuration

- 1) RP610M Probe
 - ◆ Standard stylus model: M4-P50-RB6-S36A;
 - ◆ Battery specification: 14250, 3.6V, 1000mAh; 2 ps.;
 - ◆ Usually, the probe shank is 7:24 taper shank with the BT or ISO standards , the common models are 30#,40#,50# and etc.; the shank with the HSK or other standards can also be used.
- 2) RSI-20D Receiver
 - ◆ The cable length usually is 8 meters with 13 cores' shielded cable;
 - ◆ Fixed bracket with universal adjustment function is equipped.

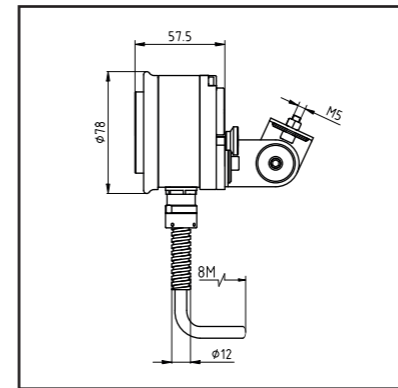

Notes:

- ◆ As for the software package, please consult the our sales staff about whether the CNC system of the machine tool can be equipped with probe; Some CNC systems needs additional settings to use probe;
- ◆ As for the probe' s taper shank, verify the standards and specifications of the spindle taper hole for the machine tool before ordering the probe; The taper shank with unusual standard or specification will lead to the probe price increase and the delivery time extend, The tapered shank we provided for the probe does not include the pull stud;
- ◆ As for function of the M code on/off, when purchasing the RPS-20M probe system, you should figure out whether there are two spare M codes in the CNC control system cabinet for the probe to use;
- ◆ As for special stylus, checking whether the standard stylus equipped with the RP610M probe can meet the requirements and thinking whether it is necessary to order a special stylus;
- ◆ As for the cable length, verify if the 8-meter cable equipped with the RSI-20 receiver is enough for installing it in the machine tool. If it is not, the additional instruction is required when ordering the product;

