

Composition of Probe System

- 1) TP200 trigger probe unit(including optional stylus);
- 2) RPD/RPDM radio signal transmitter (including customizable mounting plate);
- 3) RSI-20D radio receiver(the standard cable length 8m/the optional lengthened cable);
- 4) Software package.

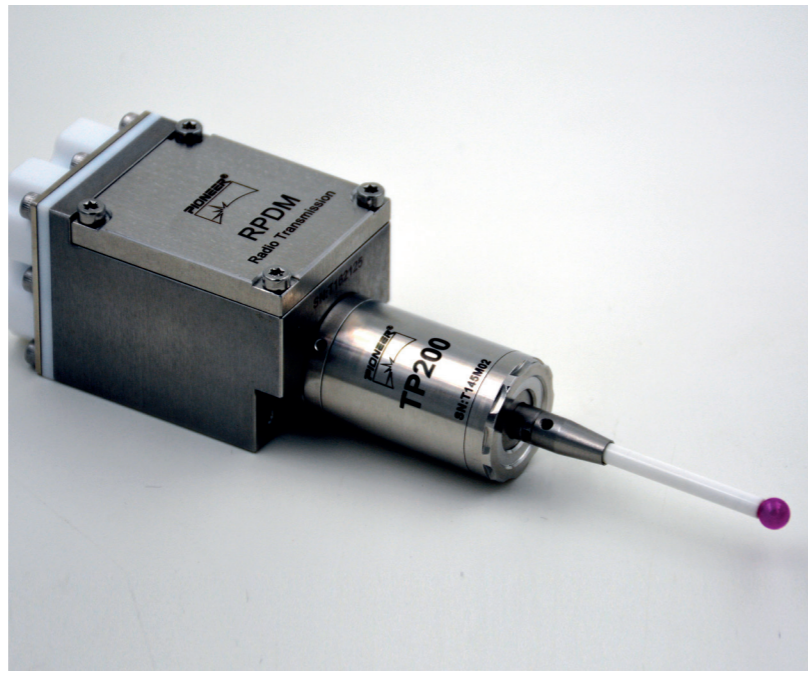
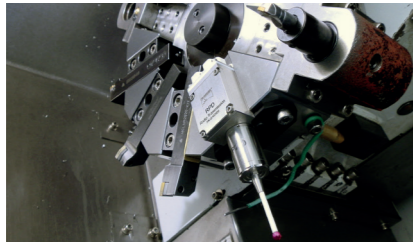

Technical Parameters

- 1) The technical parameters of TP200 trigger probe :
 - ◆ Stylus sensing direction: $\pm X, \pm Y, +Z$;
 - ◆ Stylus sensing over-travel: $X\text{-}Y \pm 12^\circ, Z +5 \text{ mm}$;
 - ◆ The trigger force in Z direction: 1000 g;
 - ◆ Trigger force in X-Y surface (standard stylus): 100-160g;
 - ◆ Unidirectional repeatability (2σ) : $\leq 1 \mu\text{m}$;
 - ◆ Seal grade: IP68.
- 2) The technical parameters of RPDM radio signal transmitter:
 - ◆ Radio signal receiving/sending distance : $\leq 14 \text{ m}$;
 - ◆ Working days of new batteries (5% utilization rate in a single shift):280-320 days;
 - ◆ Seal grade: IP68.
- 3) RSI-20D radio receiver technical parameters:
 - ◆ Radio signal receiving/sending distance: $\leq 14 \text{ m}$;
 - ◆ Input voltage is $24\text{V} \pm 10\%$ (DC) and output load current is 50 mA.
 - ◆ Seal grade: IP68.

Technical Characteristics

- ◆ The stylus connector of TP200 probe is protected by a metal cover and a rubber seal cover;
- ◆ Switch on/off method of RPDM radio signal emitter: M code on/off;
- ◆ Radio code signals are used to transmit information between RPDM radio signal emitter and the receiver. The time to transmit and to decode a group of signals is less than 1ms;
- ◆ The transmission frequency of the radio signal is within 2.4 G-2.483 G, the number of transmission channel is 16;
- ◆ Output four kinds of SSR signals to machine control system when probe is in the states of trigger. error. probe batteries low and output pulse;
- ◆ The RSI-20D receiver can change its logical state of the output signal by setting;

Applicable equipment

- ◆ Various specifications of machine center, CNC boring-milling machine, drilling machine center and so on.
- ◆ Various specifications of CNC lathes, turning machine center, CNC turning-milling machine center.

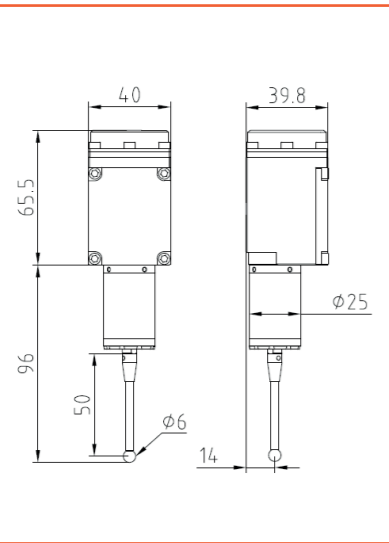

Application

- ◆ Setting work-piece coordinate system and machining zero points automatically before processing;
- ◆ Detect and control the key dimensions, position coordinates and their precision automatically between two processes;
- ◆ Detect precision of the key dimensions, shapes, position after processing.

Basic configuration

- 1) TP200 Probe
 - ◆ Standard stylus model: M4-P50-RB6-S36A;
- 2) RPDM signal transmitter
 - ◆ Battery specification: 14250, 3.6V, 1000mAh, 2 ps.;
 - ◆ The mounting plate is usually designed and made according to the specifications of customers' lathe carriages.
- 2) RSI-20D Receiver
 - ◆ The cable length usually is 8 meters with 13 cores' shielded cable;
 - ◆ Fixed bracket with universal adjustment function is equipped.



Notes:

- ◆ As for the software package, please consult the our sales staff about whether the CNC system of the machine tool can be equipped with probe; Some CNC systems needs additional settings to use probe;
- ◆ As for the mounting plate, users shall first provide us the structure diagram and specific size of the CNC lathe carriage, then we will decide whether the mounting plate of RPDM needs to be designed and manufactured all alone;
- ◆ As for function of the M code on/off, when purchasing the RPS-L11M probe system, you should figure out whether there are two spare M codes in the CNC control system cabinet for the probe to use;
- ◆ As for special stylus, checking whether the standard stylus equipped with the TP200 probe can meet the requirements and thinking whether it is necessary to order a special stylus;
- ◆ As for the cable length, verify if the 8-meter cable equipped with the RSI-20 receiver is enough for installing it in the machine tool. If it is not, the additional instruction is required when ordering the product;

